

RE 421

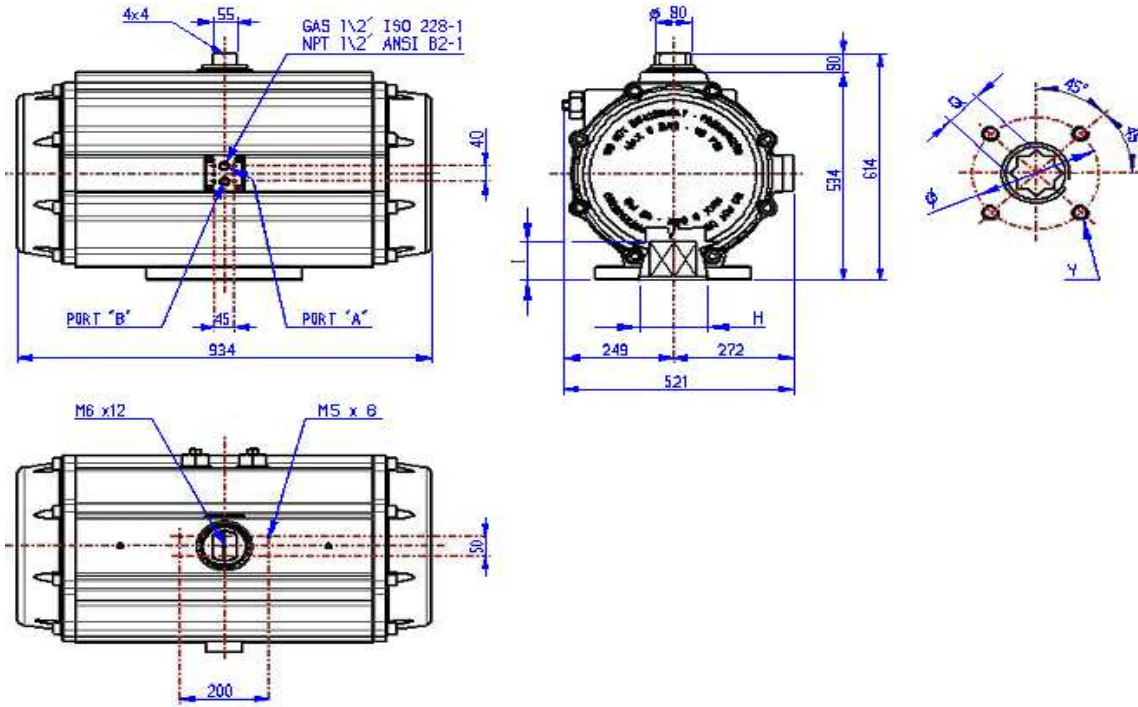

DOUBLE ACTING TORQUE RATINGS (Nm)

RE 421 DA	AIR SUPPLY IN BAR						WEIGHT kg
	3	4	5	6	7	8	
	5013,0	6684,0	8354	10025	11696	13367	210,0

SPRING RETURN TORQUE RATINGS (Nm)

RE 421 SR	AIR SUPPLY IN BAR												Torque Springs		WEIGHT kg
	3		4		5		6		7		8		90°	0°	
	0°	90°	0°	90°	0°	90°	0°	90°	0°	90°	0°	90°	90°	0°	
SR 3/3	2999	2014	4670	3685	6340	5356	8011	7026	9682	8697	11353	10368	2999	2014	244,5
SR 4/4	2327	1014	3998	2685	5669	4356	7340	6027	9011	7698	10682	9369	3999	2685	256,0
SR 5/5			3327	1685	4998	3356	6669	5027	8340	6698	10010	8369	4998	3357	267,5
SR 6/6					4327	2357	5997	4028	7668	5698	9339	7369,0	5998	4028	279,0

ADDITIONAL DATA

Chamber Diam.	420 mm
MAX.PRESSURE	8 bar
ROTATION	90° ± 5°
VOLUME	131 litres
CLOSING TIME	9,0 sek
OPENING TIME	8,0 sek
STD. GREASE	SYNTHETIC

AVAILABLE FORCE INTAKES

F25 - F30					
ISO 5211	F25		F30		
Ø	125		140		
W	M 16x24		M 20x23		
Q	55	75	75	55	75
I	60	80	80	60	80
H	200		200		