

RE 201

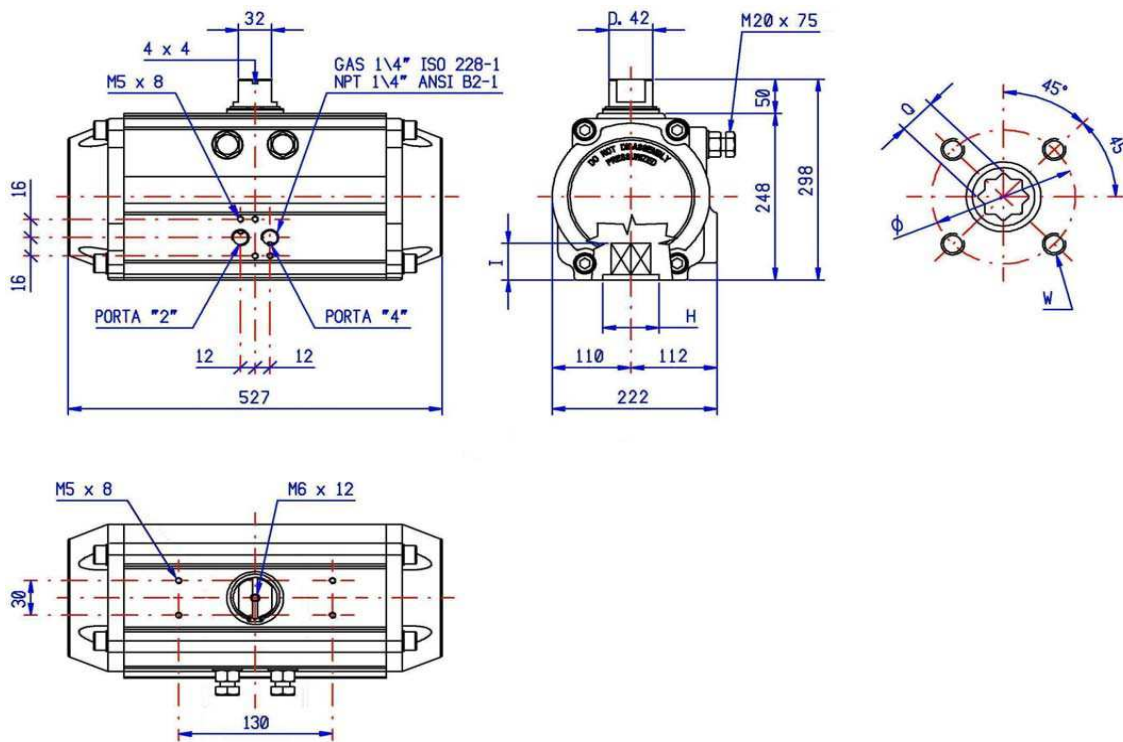

DOUBLE ACTING TORQUE RATINGS (Nm)

		AIR SUPPLY IN BAR								WEIGHT
		3	4	5	6	7	8	9	10	kg
RE 201	DA	646,0	861,3	1077	1292	1507	1723	1938	2153	36,800

SPRING RETURN TORQUE RATINGS (Nm)

		AIR SUPPLY IN BAR										Torque Springs		WEIGHT		
		3		4		5		6		7		8				kg
RE 201	SR	0°	90°	0°	90°	0°	90°	0°	90°	0°	90°	0°	90°	90°	0°	
SR 3/3		386,2	259,8	601,5	475,1	816,8	690,5	1032	905,8	1247	1121	1436	1336	386,2	259,8	
SR 4/4		299,6	131,1	514,9	346,4	730,2	561,8	945,5	777,1	1160	992,4	1376	1208	514,9	346,4	42,750
SR 5/5				428,3	217,7	643,6	433,0	858,9	648,4	1074	863,7	1290	1079	643,6	433,0	44,200
SR 6/6						557,0	304,3	772,3	519,6	987,6	735,0	1203	950,3	772,3	519,6	45,680

ADDITIONAL DATA

Chamber Diam.	200 mm
MAX.PRESSURE	8 bar
ROTATION	90° ± 5°
VOLUME	14,4 litres
CLOSING TIME	2,7 sek
OPENING TIME	3,2 sek
STD. GREASE	SYNTHETIC

AVAILABLE FORCE INTAKES

F10/12 - F14					
ISO 5211	F10		F12		F14
Ø	102		125		140
W	M 10x15		M 12x18		M 16x24
Q	27	36	27	36	27 36
I	30	39	30	39	30 39
H	85		85		100